



Syvecs Limited

Syvecs GDI4

Pinouts and Wiring Info

Support Team  
03-02-2014

This document intended for use by a technical audience and describes a number of procedures that are potentially hazardous. Installations should be carried out by competent persons only.

Syvecs and the author accept no liability for any damage caused by the incorrect installation or configuration of the equipment.

Please Note that due to frequent firmware changes certain windows might not be the same as the manual illustrates. If so please contact the Syvecs Tech Team for Assistance.

[Support@Syvecs.co.uk](mailto:Support@Syvecs.co.uk)

## Syvecs GDi4 Pinouts

### S8 Connector (Looking from the back of connector or ECU Header)

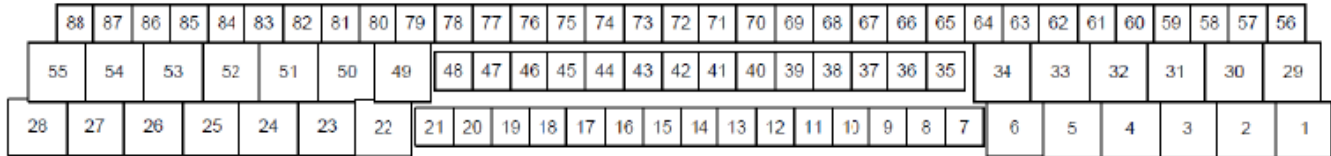

GDI4 Function	GDI4 ECU PINOUT	FUNCTION	DESCRIPTION
PWRGND	1	POWER GROUND	ECU POWER GROUND - ARE LINKED TO ALL OTHER PWRGND's ON BOARD
IGN8	2	IGNITION (20A OPEN COLLECTOR)	IGN OUT CAN DRIVE COIL DIRECTLY OR VIA TTL - SELECTABLE IN SOFTWARE, ALSO CAN BE USED TO DRIVE PWM
IGN7	3	IGNITION (20A OPEN COLLECTOR)	
IGN6	4	IGNITION (20A OPEN COLLECTOR)	
IGN5	5	IGNITION (20A OPEN COLLECTOR)	
FUEL10	6	FUEL INJECTOR (10A OPEN COLLECTOR)	SPARE PWM OUTPUT OR INJECTOR
KNK2	7	KNOCK SENSOR 2	BANK2 KNOCK SENSOR INPUT
AN16	8	CONFIGURABLE ANALOGUE INPUT	0-5V OR SPEED, FREQUENCY INPUT - PULL UP AVAILABLE IN SOFTWARE
AN14	9	CONFIGURABLE ANALOGUE INPUT	0-5V OR SPEED, FREQUENCY INPUT - PULL UP AVAILABLE IN SOFTWARE
AN12	10	CONFIGURABLE ANALOGUE INPUT	0-5V OR SPEED, FREQUENCY INPUT - PULL UP AVAILABLE IN SOFTWARE
AN10	11	CONFIGURABLE ANALOGUE INPUT	0-5V OR SPEED, FREQUENCY INPUT - PULL UP AVAILABLE IN SOFTWARE
EGT2-	12	K TYPE THERMOCOUPLE NEGATIVE INPUT	EGT2
EGT2+	13	K TYPE THERMOCOUPLE POSITIVE INPUT	EGT2
AN7	14	CONFIGURABLE ANALOGUE INPUT	0-5V OR SPEED, FREQUENCY INPUT - PULL UP AVAILABLE IN SOFTWARE
AN5	15	CONFIGURABLE ANALOGUE INPUT	0-5V OR SPEED, FREQUENCY INPUT - PULL UP AVAILABLE IN SOFTWARE
AN3	16	CONFIGURABLE ANALOGUE INPUT	0-5V OR SPEED, FREQUENCY INPUT - PULL UP AVAILABLE IN SOFTWARE
AN1	17	CONFIGURABLE ANALOGUE INPUT	0-5V OR SPEED, FREQUENCY INPUT - PULL UP AVAILABLE IN SOFTWARE
LAM1V	18	NTK UEGO SENSOR 1 NERNST VOLTAGE	GREY WIRE ON NTK L2H2 SENSOR
AN21	19	THERMISTOR INPUT	RESISTIVE 0-5V INPUTS WITH 5V PULLUP BUILT IN
FUEL15	20	FUEL INJECTOR (10A OPEN COLLECTOR)	SPARE PWM OUTPUT OR INJECTOR
RS232#1TX	21	RS232 TRANSMIT	
FUEL7	22	FUEL INJECTOR (10A OPEN COLLECTOR)	SPARE PWM OUTPUT OR INJECTOR
FUEL5	23	SPARE OUTPUT WITH FLYBACK DIODE	OUTPUT USED FOR INDUCTIVE DEVICES LIKE VVT SOLENOID
GDI #4 +	24	GDI INJECTOR +	GDI INJECTOR HIGH SIDE - SOLENOID TYPE GDI INJECTORS ONLY
GDI #3 +	25	GDI INJECTOR +	
GDI #2 +	26	GDI INJECTOR +	
GDI #1 +	27	GDI INJECTOR +	
PWRGND	28	ECU GROUNG	ECU POWER GROUND - ARE LINKED TO ALL OTHER PWRGND's ON BOARD
PWRGND	29	ECU GROUND	ECU POWER GROUND - ARE LINKED TO ALL OTHER PWRGND's ON BOARD
FUEL14	30	FUEL INJECTOR (10A OPEN COLLECTOR)	SPARE PWM OUTPUT OR INJECTOR
FUEL13	31	FUEL INJECTOR (10A OPEN COLLECTOR)	SPARE PWM OUTPUT OR INJECTOR
FUEL12 / GDI PUMP -	32	FUEL INJECTOR / GDI PUMP -	SPARE PWM OUTPUT OR INJECTOR - FITTED WITH FLYBACK DIODE TO CLAMP VOLTAGE WHEN USING GDI PUMP
FUEL11	33	FUEL INJECTOR (10A OPEN COLLECTOR)	SPARE PWM OUTPUT OR INJECTOR
FUEL9	34	FUEL INJECTOR (10A OPEN COLLECTOR)	SPARE PWM OUTPUT OR INJECTOR
KNK	35	KNOCK SENSOR SIGNAL	KNOCK INPUT 1
AN15	36	CONFIGURABLE ANALOGUE INPUT	0-5V OR SPEED, FREQUENCY INPUT - PULL UP AVAILABLE IN SOFTWARE
AN13	37	CONFIGURABLE ANALOGUE INPUT	0-5V OR SPEED, FREQUENCY INPUT - PULL UP AVAILABLE IN SOFTWARE
AN11	38	CONFIGURABLE ANALOGUE INPUT	0-5V OR SPEED, FREQUENCY INPUT - PULL UP AVAILABLE IN SOFTWARE
AN9	39	CONFIGURABLE ANALOGUE INPUT	0-5V OR SPEED, FREQUENCY INPUT - PULL UP AVAILABLE IN SOFTWARE
EGT1-	40	K TYPE THERMOCOUPLE NEGATIVE INPUT	EGT1
AN8	41	CONFIGURABLE ANALOGUE INPUT	0-5V OR SPEED, FREQUENCY INPUT - PULL UP AVAILABLE IN SOFTWARE
AN6	42	CONFIGURABLE ANALOGUE INPUT	0-5V OR SPEED, FREQUENCY INPUT - PULL UP AVAILABLE IN SOFTWARE
AN4	43	CONFIGURABLE ANALOGUE INPUT	0-5V OR SPEED, FREQUENCY INPUT - PULL UP AVAILABLE IN SOFTWARE

AN2	44	CONFIGURABLE ANALOGUE INPUT	0-5V OR SPEED, FREQUENCY INPUT - PULL UP AVAILABLE IN SOFTWARE
LAM#2V	45	NTK UEGO SENSOR 2 NERNST VOLTAGE	GREY WIRE ON NTK L2H2 SENSOR
AN22	46	THERMISTOR INPUT	RESISTIVE 0-5V INPUTS WITH 5V PULLUP BUILT IN
FUEL16	47	FUEL INJECTOR (10A OPEN COLLECTOR)	SPARE PWM OUTPUT OR INJECTOR
RS232#1RX	48	RS232 RECEIVE	
FUEL8	49	FUEL INJECTOR (10A OPEN COLLECTOR)	SPARE PWM OUTPUT OR INJECTOR
FUEL6	50	SPARE OUTPUT WITH FLYBACK DIODE	OUTPUT USED FOR INDUCTIVE DEVICES LIKE VVT SOLENOID
GDI #4 -	51	FUEL INJECTOR (10A OPEN COLLECTOR)	GDI INJECTOR HIGH SIDE - SOLENOID TYPE GDI INJECTORS ONLY
GDI #3 -	52	FUEL INJECTOR (10A OPEN COLLECTOR)	
GDI #2 -	53	FUEL INJECTOR (10A OPEN COLLECTOR)	
GDI #1 -	54	FUEL INJECTOR (10A OPEN COLLECTOR)	
PWRGND	55	ECU GND	ECU POWER GROUND - ARE LINKED TO ALL OTHER PWRGND's ON BOARD
<b>VBAT</b>	<b>56</b>	<b>ECU +12V SUPPLY</b>	<b>12V IGN SWITCH</b>
<b>VBAT</b>	<b>57</b>	<b>ECU +12V SUPPLY</b>	<b>12V IGN SWITCH</b>
GDI PUMP +	58	GDI PUMP+	GDI PUMP +
H BRIDGE2	59	H BRIDGE2	H-BRIDGE OUTPUTS, CAN BE DRIVEN HIGH OR LOW. USED GENERALLY FOR MOTOR CONTROL, PWM OUTPUT, VANOS .....
H BRIDGE3	60	H BRIDGE3 - DBW +	
H BRIDGE4	61	H BRIDGE4 - DBW -	
10VOUT	62	LOW CURRENT PROGRAMMABLE OUTPUT	PROGRAMMABLE VOLTAGE OUTPUT FOR SENSORS
5VOUT2	63	+5V SENSOR SUPPLY OUTPUT	5V REFERENCE FOR SENSORS
5VOUT1	64	+5V SENSOR SUPPLY OUTPUT	5V REFERENCE FOR SENSORS
KNKGND	65	KNOCK SENSOR GROUND	KNOCK SENSOR GROUND
AN20	66	5V ANALOGUE INPUT	0-5V INPUT
ANGND2	67	SENSOR GROUND #1	SENSOR GROUND
AN19	68	5V ANALOGUE INPUT	0-5V INPUT
ANGND1	69	SENSOR GROUND #2	SENSOR GROUND
EGT1+	70	K TYPE THERMOCOUPLE POSITIVE INPUT	
AN18	71	5V ANALOGUE INPUT	0-5V INPUT
ANGND2	72	SENSOR GROUND #2	SENSOR GROUND
AN17	73	5V ANALOGUE INPUT	0-5V INPUT
ANGND1	74	SENSOR GROUND #1	SENSOR GROUND
LAM2I	75	NTK UEGO SENSOR 2 ION PUMP	LAMBDA2 ION PUMP - WHITE WIRE ON NTK
LAMI	76	NTK UEGO SENSOR 1 ION PUMP	LAMBDA ION PUMP - WHITE WIRE ON NTK
LAMGND	77	LAMBDA SENSOR SIGNAL GROUND	LAMBDA SIGNAL GND - BLACK WIRE ON NTK
COMGND	78	RS232 COMMS GROUND	
CAN2LO	79	CONTROLLER AREA NETWORK #2 SIGNAL LOW	
CAN2HI	80	CONTROLLER AREA NETWORK #2 SIGNAL HIGH	
CAN1LO	81	CONTROLLER AREA NETWORK #1 SIGNAL LOW	
CAN1HI	82	CONTROLLER AREA NETWORK #1 SIGNAL HIGH	
AN24	83	THERMISTOR INPUT	RESISTIVE 0-5V INPUTS WITH 5V PULLUP BUILT IN
AN23	84	THERMISTOR INPUT	RESISTIVE 0-5V INPUTS WITH 5V PULLUP BUILT IN
LANRX+	85	100 BASET ETHERNET RECEIVE	LAN RECEIVE POSITIVE
LANRX-	86	100 BASET ETHERNET RECEIVE	LAN RECEIVE NEGATIVE
LANTX+	87	100 BASET ETHERNET TRANSMIT	LAN TRANSMIT POSITIVE
LANTX-	88	100 BASET ETHERNET TRANSMIT	LAN TRANSMIT NEGATIVE

## General Connections

### Connecting Power

The ECU has two power feeds, which can either be used to provide a redundant multiple feeds, or as a way of providing switched power to additional loads through the loom.

#### Example Schematic

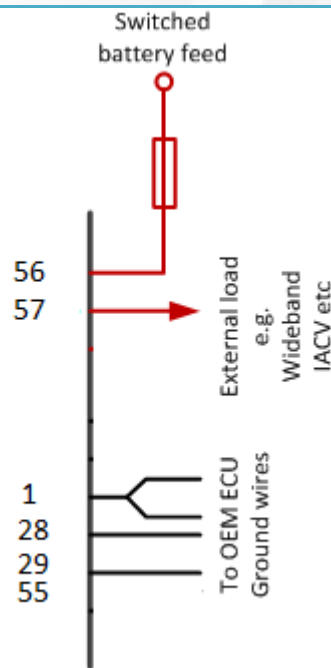

Figure 0-1 - Redundant Power Feeds and a Common grounding point.

### Pin Schedule

Pin Number	Function	Notes
56	VBAT	Use a fused Switched feed.
57	VBAT	Use a fused Switched feed.
1	Power Ground	Up to 2 ground wires can be paired to this pin.
28	Power Ground	Up to 2 ground wires can be connected to this pin.
29	Power Ground	Up to 2 ground wires can be paired to this pin.
55	Power Ground	Up to 2 ground wires can be paired to this pin.

**NOTE!** Power Grounds are designed to conduct High Current loads – Do not mix Power Grounds with Analogue (AN) Grounds.

### LAN Connection

Connection from the S6plus to a Laptop/PC uses a Male RJ45 plug, wired in cross over configuration.

### Example Schematic

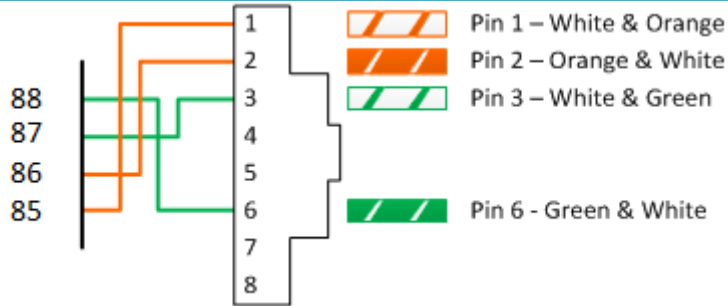

Figure 0-2 RJ45 Wiring

### Pin Schedule

Pin Number	Function	Notes
88	LAN Transmit -	RJ45 Pin 6 – Green & White wire
87	LAN Transmit +	RJ45 Pin 3 – White & Green wire
86	LAN Receive -	RJ45 Pin 2 – Orange & White wire
85	LAN Receive +	RJ45 Pin 1 – White & Orange wire

### CAN Bus

Common Area Network Bus (CAN Bus) is a widely used data interface common used in many cars and aftermarket accessories (such as Stack Data loggers and Dashes). Data is sent using the High and Low wires, which are maintained as a twisted pair.

### Example Schematic

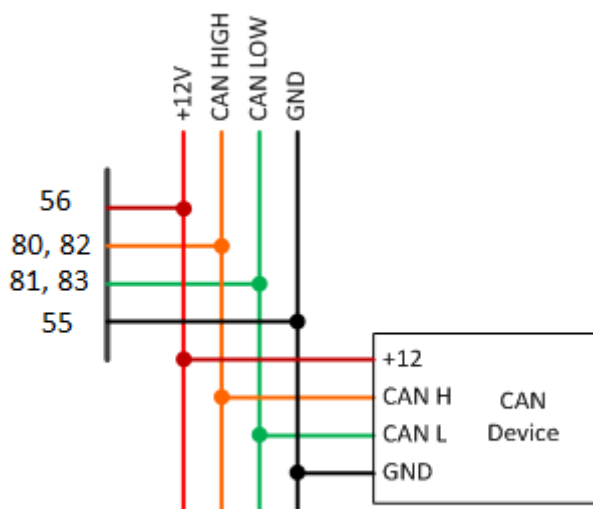

**NOTE:** CAN Wires must be kept as a twisted pair.

Pin Number	Function	Notes
80 or 82	CAN HIGH	Check OEM Colour pairing.
81 or 83	CAN LOW	Ensure wires are twisted pair.

## RS232

Telemetry can data can be provided via RS232.

### Example Schematic

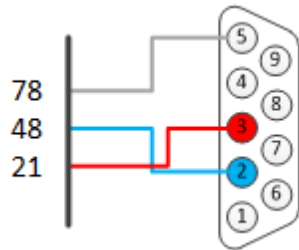

Figure 0-3 RS232 Connection

### Pin Schedule

Pin Number	Function	Notes
78	Pwr GND	DB-9 pin 5
48	Rx	DB-9 pin 2
21	Tx	DB-9 pin 3

## Input Connections

### Sensor/ Analogue Grounds (AN Grounds)

Sensors and miscellaneous analogue inputs have their own Ground pins; these grounds must be kept separate from the Power grounds shown in the first section. As there are four ground pins you may have to connect multiple grounds to some of the pins if you have more than four sensors.

### Pin Schedule

Pin Number	Function	Notes
67	ANGND2	
69	ANGND1	
72	ANGND2	
74	ANGND1	

## Assigning Inputs

The Syvecs S8 has 24 programmable inputs available and although they are fully configurable in Scal, they are not all the same type of input which means sensors that for example require a pull up, have to assigned to different types..... Listed below are the 4 types which are available.

### Bipolar Inputs

These Inputs are able to swing above and below the reference ground meaning they can see Positive Voltage as well as Negative.

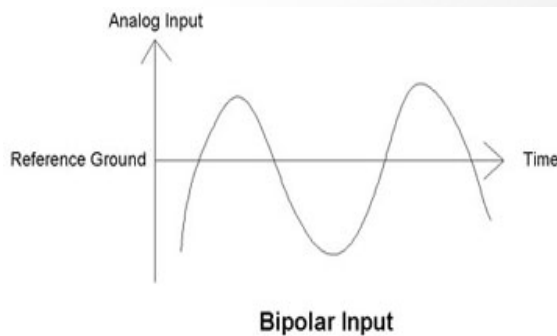

Example of sensors normally used on these Inputs are:

- Reluctor Crank and Cam Sensors
- ABS Sensors for wheel speed

Bipolar inputs are not just limited to the above they can also be used for any sensor that outputs 0-5volts. They are also able to provide a Pull-up through Scal

Pin Number	Scal Assignment	Notes
17	An01	
44	An02	
16	An03	
43	An04	
15	An05	
42	An06	
14	An07	
41	An08	
39	An09	
11	An10	
38	An11	
10	An12	
37	An13	
9	An14	
36	An15	
8	An16	

## Voltage Inputs

These Inputs are able to sense a Voltage level which is linear and does not swing

Example of sensors normally used on these Inputs are:

- Manifold Pressure sensors
- Throttle Positions
- Oil Pressures

Voltage Inputs are not just limited to the above then can also be used for any sensor which outputs a 0-5volt signal but NOT able to provide a pull up.

Pin Number	Scal Assignment	Notes
73	An17	
71	An18	
68	An19	
66	An20	

## Resistive Inputs

These Inputs are the same as voltage inputs in which they can accept a 0-5v but they have a fixed 3k 5v Pull up fitted

.Example of Sensors normally used on these Inputs are:

- Temperature sensors
- Calibration switches

Pin Number	Scal Assignment	Notes
19	An21	
46	An22	
84	An23	
83	An24	



## Sensor Schematics - Examples

### Crank Sensor – Magnetic Type

#### Example Schematic

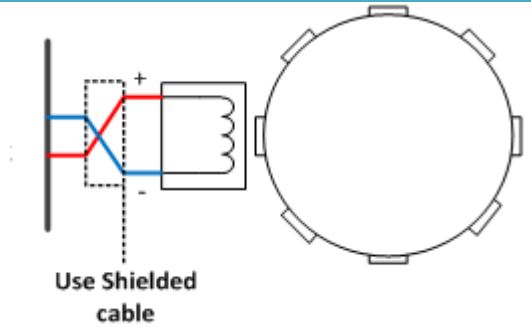

#### Pin Schedule

Pin Number	Function	Notes
74	ANGND1	Crank Sensor – (Shared with Cam Sensor)
41	Bipolar Input	Crank Sensor+

### Cam Sensors – Magnetic Type

#### Example Schematic

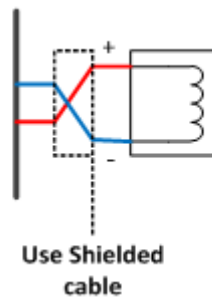

#### Pin Schedule

Pin Number	Function	Notes
74	ANGND1	Cam Sensor – (Shared with Crank Sensor)
42	Bipolar input	Cam Sensor +

## Manifold Pressure Sensor (MAP)

### Example Schematic

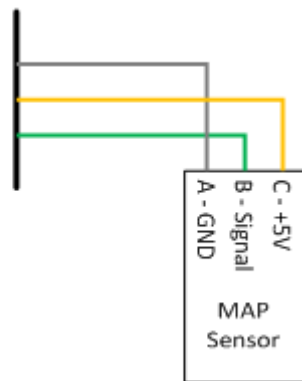

### Pin Schedule

Pin Number	Function	Notes
74	ANGND1	May be shared with multiple sensors
64	5VOUT1	Regulated sensor power supply
71	Voltage Input	Can use Bipolar, Unipolar or Voltage inputs

## Throttle Position Sensor (TPS)

### Example Schematic

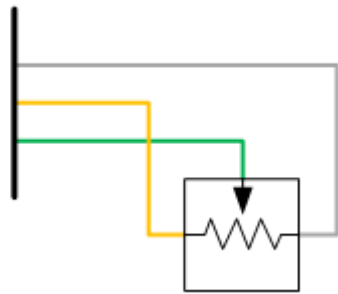

### Pin Schedule

Pin Number	Function	Notes
74	ANGND1	May be shared with multiple sensors
64	5VOUT1	Regulated sensor power supply
73	Voltage Input	Can use Bipolar, Unipolar or Voltage inputs

## Coolant Temperature Sensor (CTS)

### Example Schematic

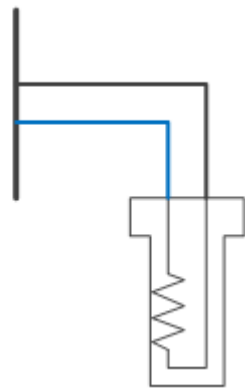

### Pin Schedule

Pin Number	Function	Notes
74	ANGND1	May be shared with multiple sensors
84	Resistive Input	Can use Resistive inputs #1 to #4 (pins 63 to 66)

## Inlet Air Temperature Sensor (IAT)

### Example Schematic

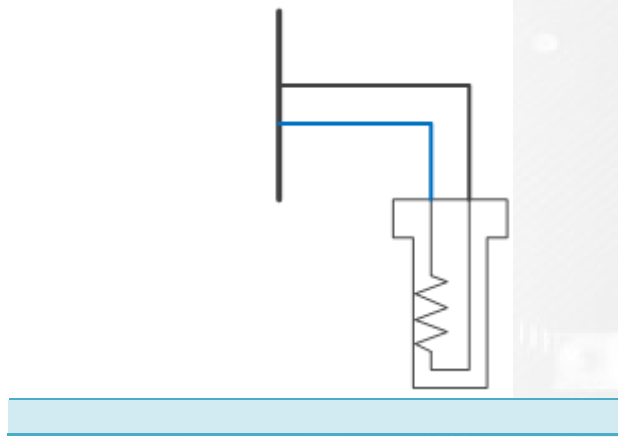

### Pin Schedule

Pin Number	Function	Notes
74	ANGND1	May be shared with multiple sensors
83	Resistive Input	Can use Resistive inputs #1 to #4 (pins 63 to 66)

## Calibration Switches

### Example Schematic

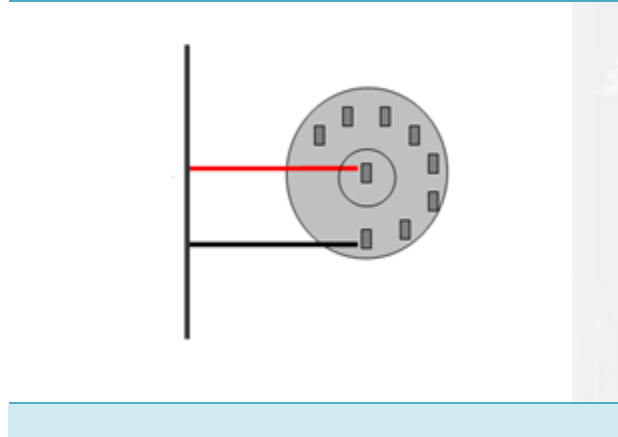

### Pin Schedule

Pin Number	Function	Notes
74	ANGND1	May be shared with multiple sensors
19	Resistive Input	Can use Resistive inputs #1 to #4 (pins 63 to 66) Cal Switches Require Pull Up to be On

## Narrowband Lambda Sensor

### Example Schematic

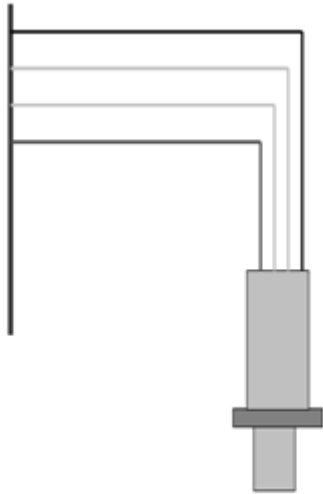

### Pin Schedule

Wire Colour	Function	Pins Usable on S8
White	Heater	56, 57
White	Heater Drive	Any FUEL Output – Needs to be assigned in Scal on I/O Configuration
Black	Signal Ground	77
Grey	Lambda Signal	Can use Bipolar, Unipolar or Voltage inputs

## Wideband Lambda Sensor

The Syvecs S8 has the ability to drive a NTK Wideband and Bosch LSU 4.2/4.9.

### Example Schematic

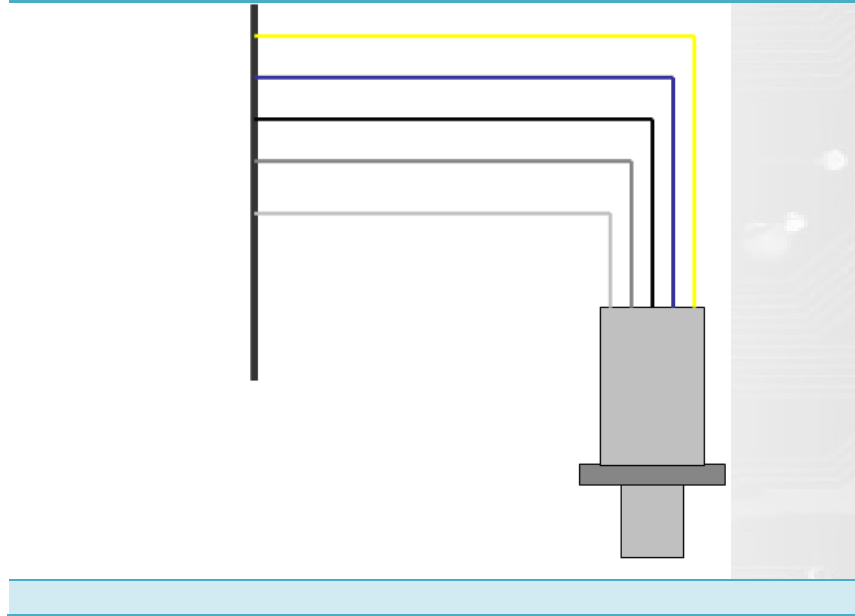

### WARNING

Due to all the different Wideband Lambda sensors requiring different hardware to work, a few solder bridges need to be changed to suit the sensor type.

See Solder Bridge Section!

Mounting recommendation

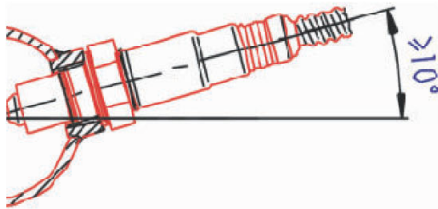

Recommended materials for the mating thread in the exhaust pipe  
\*: THexagon > 600°C or  
TGas > 930°C

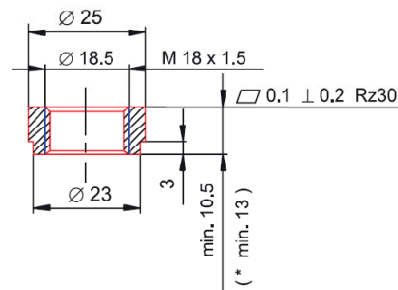

**NTK L1H1**

Lambda Sensor Input in Scal - Pin assignments needs to be Set to Lam1V or Lam2v, Lambda Heater Needs to be assigned to a Fuel Output

Lambda Pin Number	Colour	Name	S8 Pin
1	Yellow	Heater	56, 57
2	Orange	Heater Drive	Any Fuel or Pwm
6	Red	Nernst Cell Voltage	18, 45
7	White	Ion Pump Current	75, 76
8	Black	Signal Ground	77

**NTK L2H2**

Lambda Pin Number	Colour	Name	S8 Pin
1	Yellow	Heater	56, 57
2	Blue	Heater Drive	Any Fuel or Pwm
6	Grey	Nernst Cell Voltage	18, 45
7	White	Ion Pump Current	75, 76
8	Black	Signal Ground	77

**BOSCH LSU4.2**

Lambda Sensor Input in Scal - Pin assignments needs to be Set to Lam1V or Lam2v, Lambda Heater Needs to be assigned to a Fuel Output

Lambda Pin Number	Colour	Name	S8 Pin
1	Black	Nernst Cell Voltage	18, 45
2	Green	Cal Resistor	
3	Grey	Heater 12v	56, 57 or 12v
4	White	Heater Drive	Any Fuel or Pwm
5	Yellow	Signal Ground	77
6	Red	Ion Pump Current	75, 76

**BOSCH LSU4.9**

Lambda Pin Number	Colour	Name	S8 Pin
1	Red	Ion Pump Current	75, 76
2	Yellow	Signal Ground	77
3	White	Heater Drive	Any Fuel or Pwm
4	Grey	Heater 12v	56, 57 or 12v
5	Green	Cal Resistor	
6	Black	Nernst Cell Voltage	18, 45

### Knock Sensor

Syvecs S8 has two Knock inputs for a piezoelectric Example Schematic

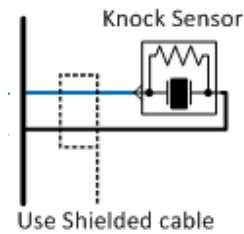

### Pin Schedule

Pin Number	Function	Notes
35	Knock 1 Signal	
7	Knock 2 Signal	
65	Knock Grounds	

**NOTE:** Shield wires should be connected only at one end, common practice is to join shielding wires at the ECU end of the loom and connect them to a Power Ground wire.

### EGT/Thermocouple

Syvecs S8 has 2 K-type thermocouple inputs.

### Example Schematic



### Pin Schedule

Pin Number	Function	Notes
70, 13	THER+	Green wire (K-type)
40, 12	THER-	White wire (K-type)



## Driven/Output Connections

### Ignition

The ignition channels are logic level outputs and IGBT designed to control ignition coils via an additional igniter (Power transistor) or Direct. These outputs can be used to drive up to 10A Peak / 5A Continuous if driving a IGBT Coil, 40ma is TTL

Adjusting the Ignition Output control is found under I/O Configuration in Scal

### Pin Schedule

Pin Number	Function	Notes
5	IGN5	Logic Level (5V) output OR IGBT
4	IGN6	Logic Level (5V) output OR IGBT
3	IGN7	Logic Level (5V) output OR IGBT
2	IGN8	Logic Level (5V) output OR IGBT

### Fuel Outputs

The Injection channels on the GDI4 are able to Drive High Impedence injectors Only. When using Low Impedence injectors we suggest a Ballast pack or use our 6 Channel Peak and Hold Driver.

Fuel Outputs also have full pulse width modulation available. These outputs can be used to drive up to 10A Peak / 5A Continuous and can only pull to ground.

**FUEL 5 & 6 HAVE FLYBACK DIODES FITTED FOR USE WITH INDUCTIVE DEVICES LIKE VVT SOLENOID**

### Pin Schedule

Pin Number	Function	Notes
23	Fuel5	PWM – Flyback Diode Present
50	Fuel6	PWM – Flyback Diode Present
22	Fuel7	Injector Output or PWM
49	Fuel8	Injector Output or PWM
34	Fuel9	Injector Output or PWM
6	Fuel10	Injector Output or PWM
33	Fuel11	Injector Output or PWM
32	Fuel12	Injector Output or PWM
31	Fuel13	Injector Output or PWM
30	Fuel14	Injector Output or PWM
20	Fuel15	Injector Output or PWM
47	Fuel16	Injector Output or PWM

### Half Bridge Outputs

An **H bridge** is an electronic circuit that enables a voltage to be applied across a load in either direction. These circuits are often used to drive Electronic Throttle bodies applications to allow DC motors to run forwards and backwards.

Half Bridge Outputs also have full pulse width modulation available and can be driven to 12v or Ground

These outputs can be used to drive up to 10A Peak / 5A Continuous

#### Pin Schedule

Pin Number	Function	Notes
58	H-Bridge1	Can be driven to 12v or Ground
59	H-Bridge2	Can be driven to 12v or Ground
60	H-Bridge3	Can be driven to 12v or Ground
61	H-Bridge4	Can be driven to 12v or Ground

### GDI Injectors

The GDI4 can drive 4 solenoid type GDI Injectors direct from the ecu, power levels for controlling these can also be adjusted in Scal - i/o configuration

#### Pin Schedule

Pin Number	Function	Notes
24	GDI 4 +	GDI Solenoid Injector +
25	GDI 3 +	GDI Solenoid Injector +
26	GDI 2 +	GDI Solenoid Injector +
27	GDI 1 +	GDI Solenoid Injector +
51	GDI 4 -	GDI Solenoid Injector -
52	GDI 3 -	GDI Solenoid Injector -
53	GDI 2 -	GDI Solenoid Injector -
54	GDI 1 -	GDI Solenoid Injector -

### GDI Pump

The GDI4 can drive 1 High pressure GDI pump direct by connecting the High Side and Low Side of the Solenoid

#### Pin Schedule

Pin Number	Function	Notes
32	GDI Pump -	Low Side Output
58	GDI Pump +	High Side Output