

CKPE06-XX - LINKAGE KIT FLAT - PORSCHE HERITAGE

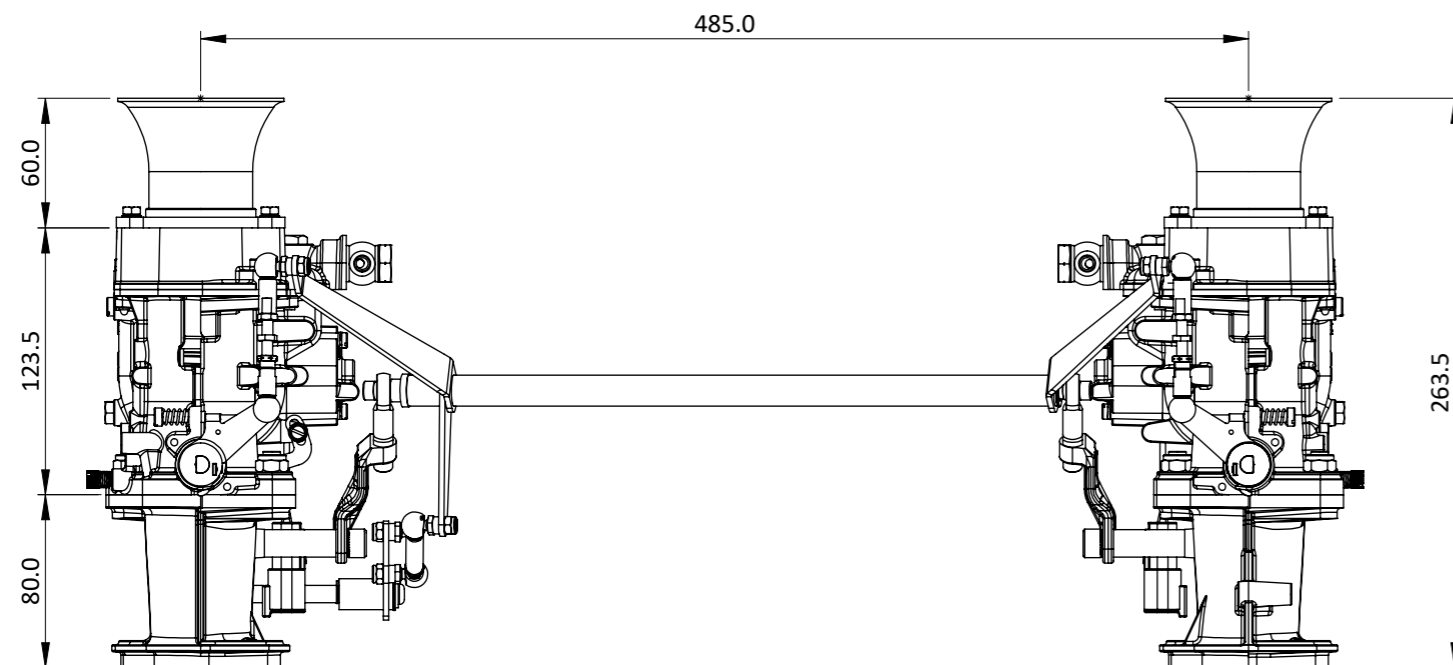

Engineered to win

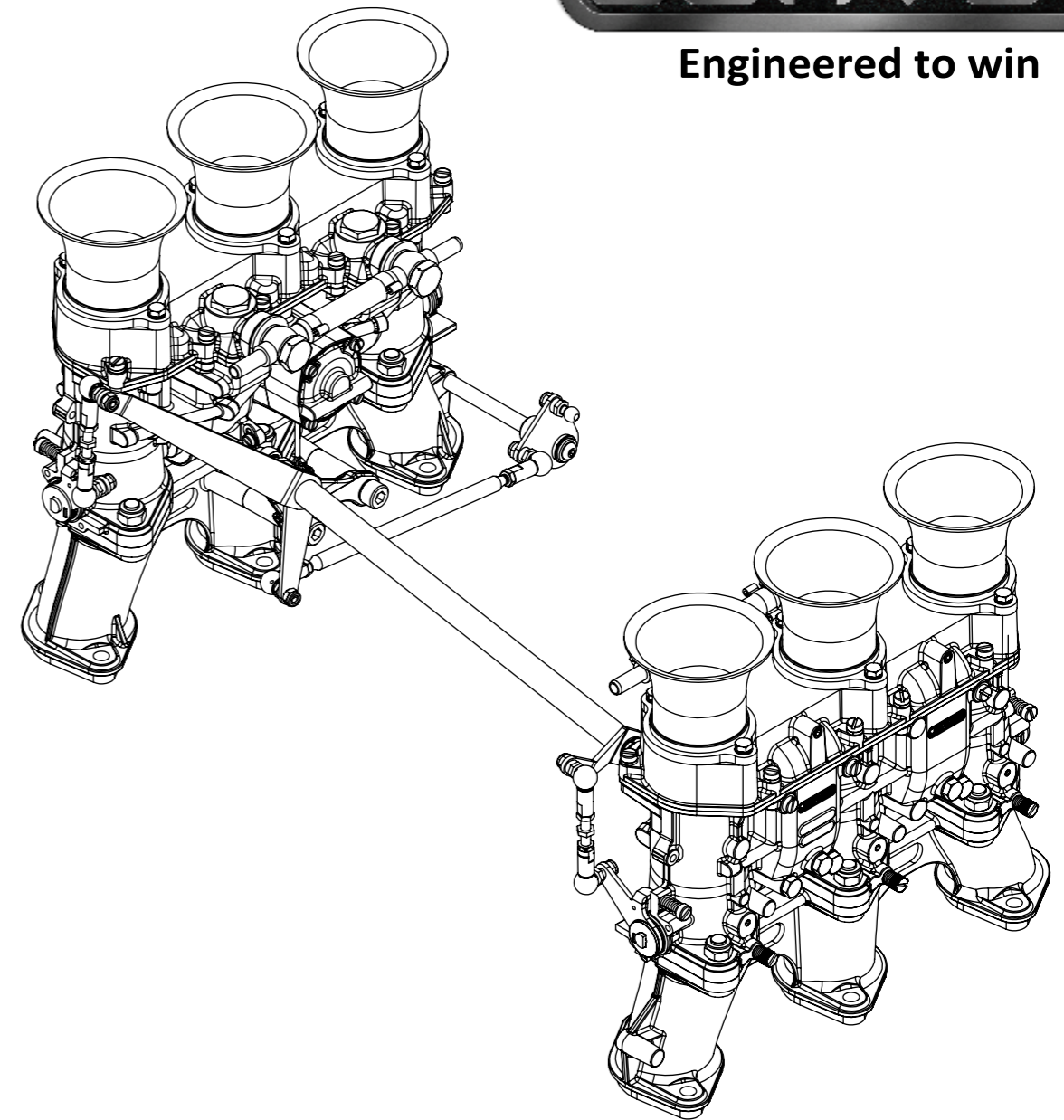
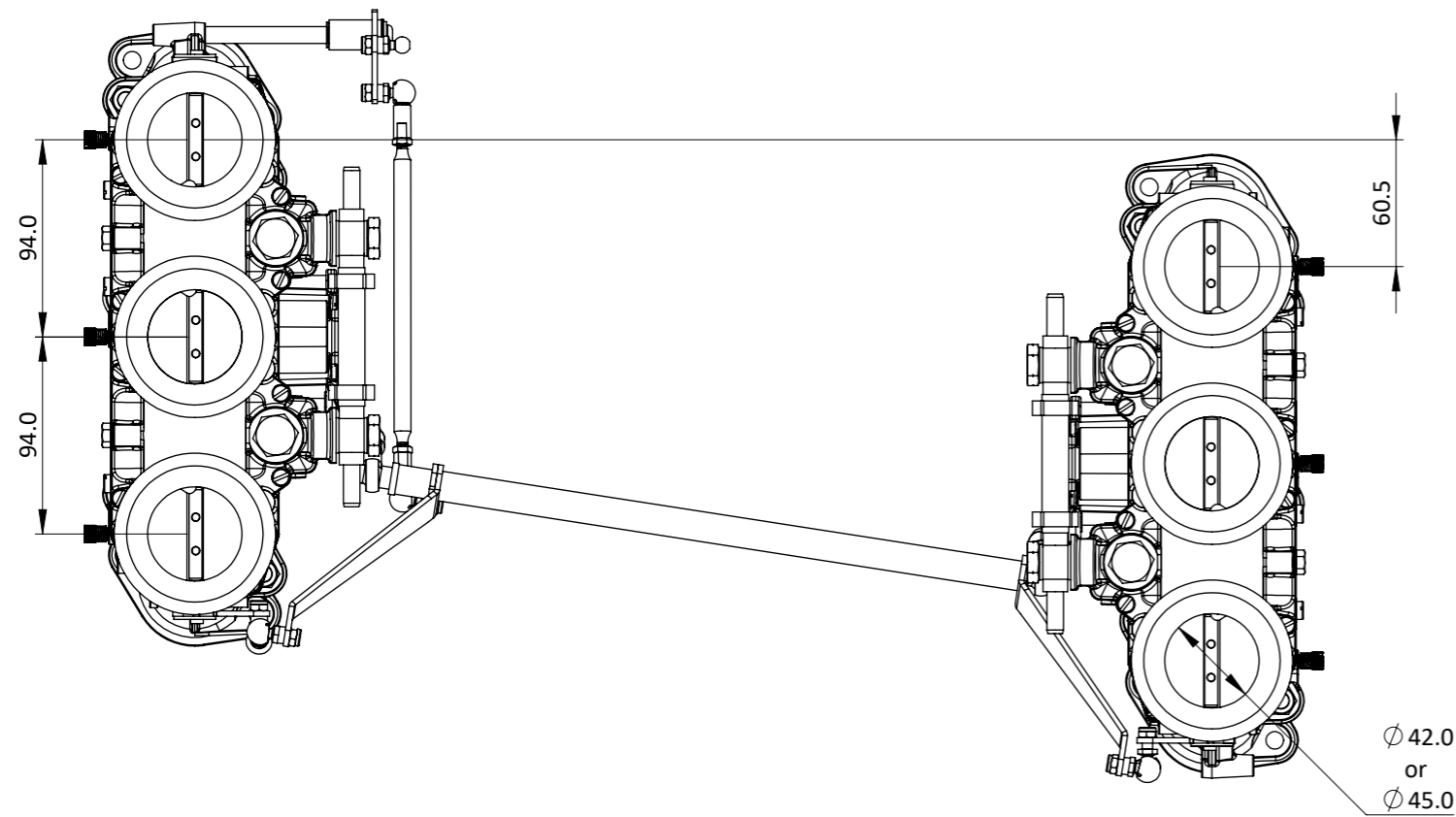

The Heritage triple body is designed with major dimensions identical to triple vertical carburetors from Weber.

Bodies are available in $\varnothing 42$ or $\varnothing 45$ with manifold outlet $\varnothing 35$ or $\varnothing 39$

The fuel rail is integrated within the body lid, supplied with Bosch EV14 350cc/min (237g) injectors. Resistance 12 Ohm

The body comes with idle bypass adjustment, interconnecting link, internal throttle positioning sensor & injector loom with a 4 pin Deutsch DTM male connector.

Spindle rotation: 82 degrees. TP goes from 3.35 V at idle to 0.65 V open.

All bodies have been balanced and tested before leaving the factory.

Frame: 1 of 1

Version: 2

Tel 01746 768810

© JENVEY DYNAMICS LTD. 2015

Web WWW.JENVEY.CO.UK

